

FXL(i) FAN STORAGE HEATER RANGE



**MODELS: FXL18i - 2.6kW / 18kWh STORAGE & 1.5kW BOOST
FXL24i - 3.4kW / 24kWh STORAGE & 1.5kW BOOST**

INSTALLATION AND OPERATING INSTRUCTIONS

IMPORTANT

**PLEASE READ THIS LEAFLET CAREFULLY AND RETAIN FOR FURTHER USE.
NOTE ALSO THE INFORMATION GIVEN ON THE HEATER**

FXL(i) FAN STORAGE HEATER RANGE



**MODELS: FXL18i - 2.6kW / 18kWh STORAGE & 1.5kW BOOST
FXL24i - 3.4kW / 24kWh STORAGE & 1.5kW BOOST**

INSTALLATION AND OPERATING INSTRUCTIONS

IMPORTANT

**PLEASE READ THIS LEAFLET CAREFULLY AND RETAIN FOR FURTHER USE.
NOTE ALSO THE INFORMATION GIVEN ON THE HEATER**

- ✦ The Installation must be carried out by trained personnel in accordance with Australian wiring rules AS/NZS 3000.
- ✦ A means for disconnection must be incorporated in the fixed wiring in accordance with the said rules.
- ✦ The heater must not be installed immediately below a fixed socket outlet.
- ✦ Do not position the heater under windows where curtains can contact the heater casing. Maintain a minimum distance of 150mm at all times between the heater and combustible materials, such as furniture and curtains.
- ✦ **WARNING** in order to avoid overheating, do not cover the heater. Do not place objects in contact with the heater.

- ✦ **WARNING - THE SURFACES ON THIS HEATER CAN BE HOT.**
- ✦ This heater meets AS/NZS 60335 electrical safety requirements. However, any heater type becomes hot in normal operation. Care must be taken to ensure that prolonged skin contact with the heater does not occur.
- ✦ **WHERE YOUNG CHILDREN, INFIRM PERSONS, OR THE AGED ARE PRESENT THIS APPLIANCE MUST BE ADEQUATELY GUARDED.** Contact your installer or the manufacturer for further advice.

This appliance is not intended for use by persons (including children) with reduced physical, sensory or mental capabilities, or lack of experience and knowledge, unless they have been given supervision for instruction concerning use of the appliance by a person responsible for their safety. Children should be supervised to ensure that they do not play with the appliance.
- ✦ This appliance is very heavy and must be securely fixed to a wall. **DO NOT UNDER ANY CIRCUMSTANCES ATTEMPT TO MOVE OR REPOSITION THIS HEATER WITHOUT SEEKING EXPERT ADVICE.**
- ✦ To maintain stability, it is essential that the heater is placed on a level surface and care should be taken to avoid irregular surfaces, such as may result from carpets or tiled surrounds partially protruding under the heater.
- ✦ This heater must be installed where it is impossible for switches and other controls to be touched by a person using a bath or shower.
- ✦ **IMPORTANT -** Due to the newness of materials the heater will produce a slight smell for the first few days of operation. **ROOMS MUST BE WELL VENTILATED AND YOUNG CHILDREN, CAGED BIRDS, OR PERSONS WITH RESPIRATORY COMPLAINTS MUST NOT REMAIN IN CLOSE PROXIMITY TO THE HEATER DURING THE FIRST 48 HOURS OF THE COMMISSIONING PERIOD.**
- ✦ **IF, DURING ANY REASSEMBLY OF THE HEATER, A PART OF THE THERMAL INSULATION SHOWS DAMAGE OR DETERIORATION WHICH MAY IMPAIR SAFETY, IT SHOULD BE REPLACED BY AN IDENTICAL PART.**



IMPORTANT WARNING

FAILURE TO FOLLOW THESE INSTRUCTIONS

WILL VOID THE WARRANTY

Possible problem with FXL Fans

- Some output fans have not worked or run slowly when first turned on due to stiff bearings.
- This results in the boost element overheating and burning out when the BOOST switch is turned on.

BEFORE CONNECTING PEAK POWER ENSURE THAT THE BOOST SWITCH IS IN THE OFF POSITION
(The Boost Switch is on the Right Hand End Panel of the heater).

REMEDY: Run the fan at Full Speed with the Boost Element Disconnected

1. Isolate the heater from power, disconnect both sections of the Boost Element at the connection strip adjacent to the fan compartment, reconnect the power and turn the Boost Switch ON. This will apply full voltage to the fan without energising the Boost Element and it should start on high speed. Once you have felt rapid air flow allow the fan to run for a few minutes then isolate the power and reconnect the Boost Element
2. If Procedure 1 does not work, isolate the heater from power, remove the black fan compartment cover (4 screws) and gently move the drum back and forth with a finger or a small screwdriver.
Then repeat Procedure 1.

Following success with these procedures test the Boost Element with the fan running by turning the BOOST switch on. The fan speed will increase and heat should be felt immediately.

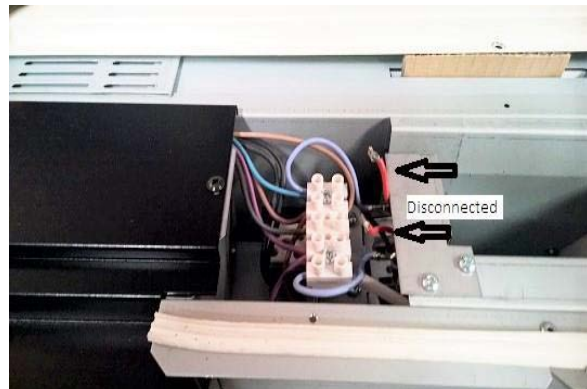

Access the drum between the drum casing and the heater body

INSTALLATION INSTRUCTIONS

STORAGE CIRCUIT

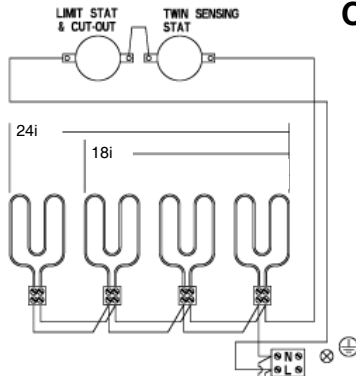

FAN/BOOST CIRCUIT

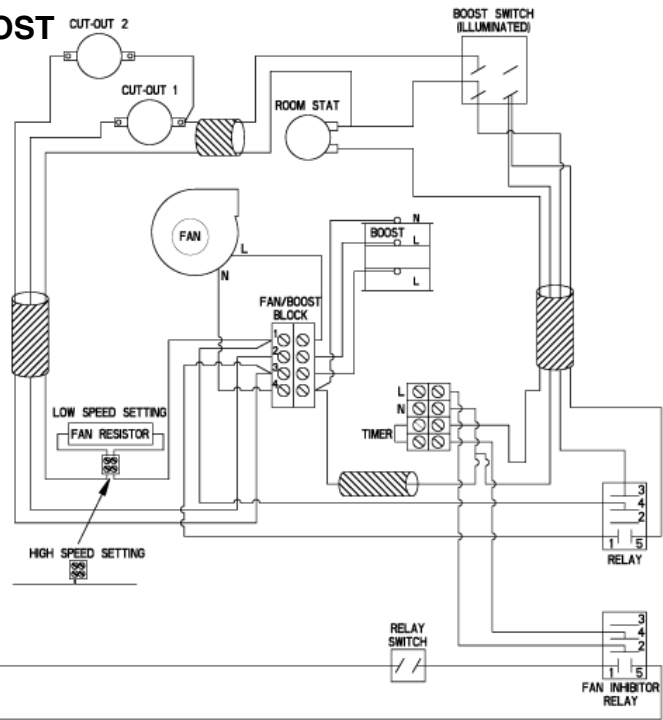

PREPARATION

The heater will arrive separately from its storage bricks, the following bricks will be required.

FXL18i - 12 bricks
FXL24i - 16 bricks

IMPORTANT DURING NORMAL OPERATION ENSURE BOTH SUPPLIES ARE SWITCHED ON AT THE WALL.

Two supplies are required for the operation of this heater - a restricted Off Peak or Economy 7 supply for the storage circuit, and an unrestricted supply for the fan boost element circuit.

Thermostatic fan / boost control is provided on the heater, however the fan / boost operation may be customised by the introduction of an external timer to the heater (see section 3).

WARNING - This appliance must be earthed

Only heat resisting cable (min. rating V75) should be used. The wires in the mains cable will be coloured as follows:-

GREEN & YELLOW - EARTH
BLUE - NEUTRAL
BROWN - LIVE

SUGGESTED FIXINGS

SOLID BRICK/BLOCK - No. 10 Size plastic inserts, 8mm drill bit. Drill hole 15mm deeper than plastic insert length.

PLASTERBOARD - If possible locate studding and use No. 10 woodscrews directly into the wood, otherwise M5 rawlplug intersets are suitable.

NOTE: FOR OTHER WALL TYPES - (e.g. timberframe and hollow concrete) **SEEK SPECIALIST ADVICE.**

INSTALLATION

1. ENSURE THAT FIXING KIT HAS BEEN LOCATED BEFORE DISPOSING OF PACKAGING.

Remove the front panel by removing the three screws along its bottom edge. With hands positioned on each side of the panel, lift upwards to unhook the top edge whilst pressing down on the top panel with your thumbs. The panel can now be lifted clear and set to one side.

Remove the packing pieces from the slots on the inner front (3 on the FXL18i and 4 on the FXL24i).

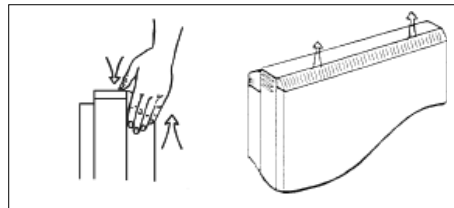

2. Remove the inner front panel by unscrewing the screws along its top and sides. As the front insulation is attached care must be taken when lifting this panel from the heater and placing it to one side.

Remove the three inner guards by removing the screws along their bottom edges and sliding the guards up and off the base tray. **Please note the location of each guard.**

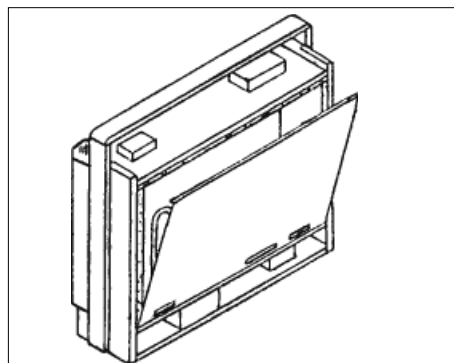

3. CONNECTION OF THE MAINS CABLE

- Connect the restricted (E7) supply to the terminal block, marked "Storage Circuit", having first passed the cable through a front cable clamp in the base. Connect the unrestricted (Peak) supply to the terminal block, marked "Fan/Boost Circuit", having passed this cable through another cable clamp in the base.

At this point, if desired, an external fan/boost timer may be fitted to the heater by passing the two wires from the timer through the remaining cable clamp, and connecting them across the terminal block, marked "Timer", having already removed the link fitted across this block at the factory.

IMPORTANT: When using an external fan/boost timer, the fan inhibitor must be disabled (see Section 4).

Connect the EARTH lead from both supplies to the terminal marked with the symbol 

STRIPPING DETAIL

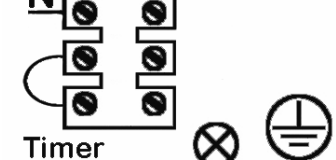
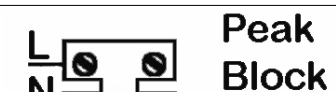
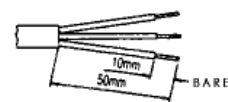

4. The heater is fitted with a fan inhibitor relay. This relay will inhibit the operation of the fan during the off peak periods. If the fan operation is required (eg. if using external fan/boost timer) during the off peak period then the relay switch should be switched to the relay off position.

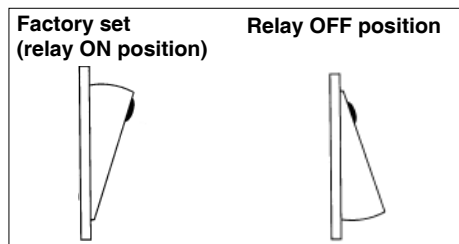

5. **FAN SPEED SELECTION** - At this point the installer must choose between **Normal/High Fan** or permanent **High Fan** option.

Option 1 - The heater is factory set at **Normal Fan**. The fan will therefore:-

- Run at **NORMAL** when the boost option is not selected.
- Run at **NORMAL** when the boost is selected and the core is partially depleted.
- Automatically switch to **HIGH** when the boost is selected and the core is almost fully depleted.

Option 2 - If a **High Fan** is permanently required the installer must make the following adjustment.

- Loosen the two screws securing the wires to the resistor block.
- Move the right wire to the left of the block and tighten both wires in the left connection point of the resistor block effectively taking the resistor out of circuit.

See Fan/Boost Circuit Diagram

6. Ensure that any slack is pulled back through each clamp and tighten the clamping screws. Secure cables to base of heater using ties provided in fixing kit.

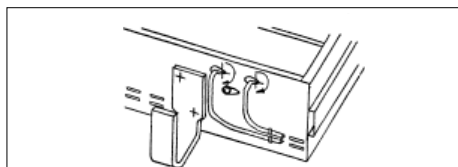

7. Place the heater on its feet, and in the desired position against the wall - **DO NOT LIFT THE HEATER BY ITS TOP PANEL!** Ensure that the heater is based on a firm level surface, at least 100mm from any end wall, and at least 100mm below any shelf or similar projection. Cut away the gripper rod or carpet which would prevent the heater sitting firmly on the floor.

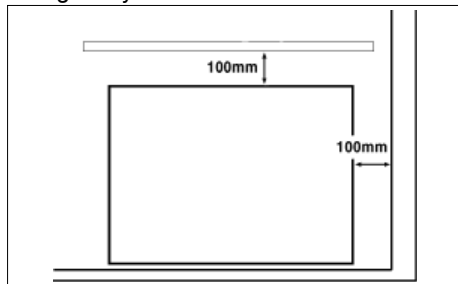

8. Mark the position of the two outside corners of the wall bracket with the heater pushed tight against the wall. Remove the wall bracket from the heater by removing the screw at each end. Place the heater to one side and reposition the bracket against the wall using the corner marks for alignment.

Four fixing positions must be chosen for the FXL24i and three for the FXL18i. Mark the positions for the fixing holes - two at the extreme ends and others spaced evenly between them. Remove the bracket from the wall, drill the holes in the positions marked, and insert suitable fixings previously described. Secure the wall bracket to the wall using the correct fasteners.

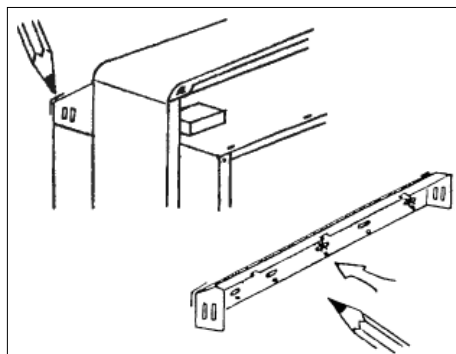

9. **THE FOLLOWING MUST BE APPLIED WHEN FIXING THE HEATER TO THE WALL BRACKET.**

- If no skirting board is present secure the heater through the wall bracket slots closest to the wall.
- If 100mm (4 in.) skirting is present secure the heater through the outer slots.
- If skirting taller than 150mm (6 in.) is present this must be reduced to 150mm (6 in.) over the entire width of the heater plus 25mm (1 in.) at each end.

Do not fully tighten these screws until the bricks are loaded into the heater as some settling of the heater may occur.

NOTE: NEVER REMOVE THESE SCREWS WITHOUT FIRST UNLOADING THE HEATER.

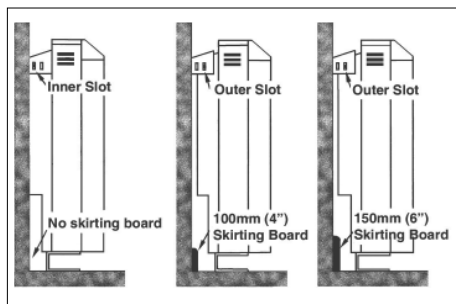

10. Remove one element to allow access for the back rows of bricks. On the FXL24i remove the element to the right of centre and on the FXL18i remove the central element.

Loosen the two screws securing the element tails in the ceramic connector block, and lift the element up and out of the heater.

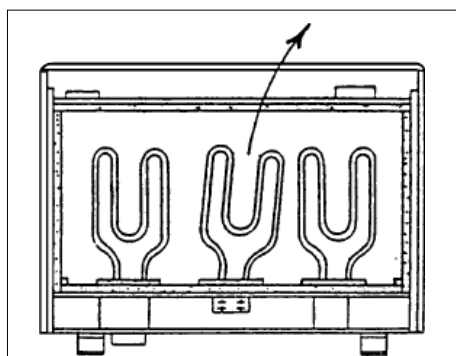

11. Carefully fit the bottom row of the back layer of bricks placing the two end bricks into position first. **Ensure that the recess in the bricks is toward the rear of the heater with the narrow end to the bottom. Repeat this with the top row of the back layer of bricks but the narrow end of the recess must be to the top.**

Refit the element which had been removed by feeding the tails down through the hole in the base insulation and into the connector block. Ensure the element is fully pushed home, then securely tighten the two screws in the block.

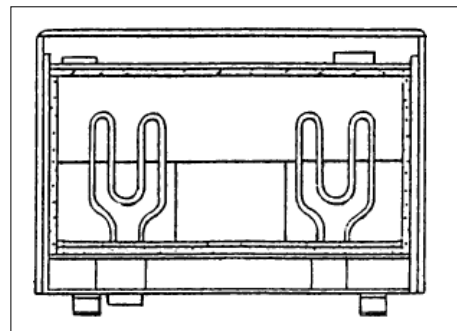

12. Fit the front layer of bricks with the recess toward the front of the heater.

The complete core will comprise:

FXL18i : 3 x 4 brick columns

FXL24i : 4 x 4 brick columns

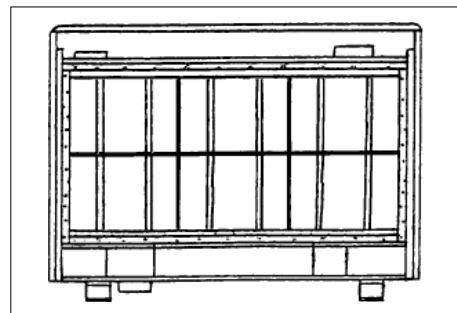

13. Replace the inner front, complete with insulation, by locating its bottom edge behind the front lip of the chassis and inserting the retaining screws along the top and sides.

Refit the three inner guards in their respective locations.

Replace the outer front by hooking the upper grille into its retaining slot on the top panel, lower into position and replace the three self tapping screws along the bottom edge.

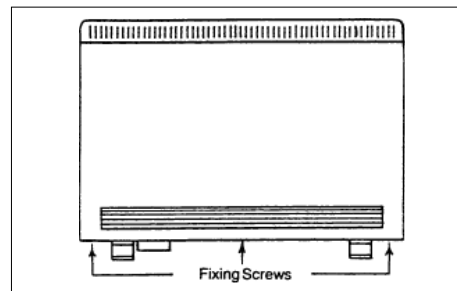

14. Finally, tighten the screws at each end of the wall bracket. Ensure that all screws have been tightened as this is essential to maintain earth continuity.

OPERATING INSTRUCTIONS

Principles of Operation

Heat Retention

This storage heater takes in energy when electricity tariffs are low, and retains it in the insulated core.

Automatic Input Control

An automatic input control system varies the charge taken in response to weather conditions, taking into account the amount of energy already stored in the heater. It therefore provides an economic heating system requiring no adjustment by the user.

Core Discharge

A thermostatically controlled fan draws air through the hot core, releasing the stored heat as and when required, providing a level of room temperature control superior to that of conventional storage heaters.

Boost Heating

A supplementary direct acting element provides additional boost heating when required. Although this may function outside reduced tariff periods, the boost will **only** operate when the more economical 'stored energy' is exhausted.

Safety Instructions

1. Ventilate rooms well during commissioning.
2. Do not move the heater in any way once installed without the services of a competent electrician.
3. Do not cover the heater with clothing etc. at any time, or position furniture close to, or against, the heater.
4. Ensure clearances of at least 150mm between the heater and curtains.

ALSO REFER TO COVER PAGE

Commissioning (first 48 hours of use)

Due to the newness of materials, the heater will produce a slight smell for the first few days of operation. In order to dispel these odours as quickly as possible:

(i) During the day set the input room temperature control to MAXIMUM and the boost switch to OFF, allowing the fan to run as often as possible.

(ii) During the night, ensure that the boost switch is set to OFF, and reduce the room temperature control setting to MINIMUM to enable the core to accept its full charge.

Ensure both supplies are switched on at the wall.

Normal Use (after the first 48 hours)

- i) Keep both supplies switched on at the wall.**
- ii) When only background heat is required (eg. when the room is unoccupied) set the temperature control to minimum.
- iii) When more heat is required in the room (eg. when the room is occupied) turn the temperature control to 5 or 6 to set the required room temperature.
- iv) At night time, set the temperature control back to MINIMUM, to allow the heater to accept its full charge.

Control Functions

Setting the Controls

The controls are located at the top right hand corner of the heater, both under the hinged flap, and on the side panel.

Input Controls

This heater is fitted with a user adjustable automatic input control which varies the charge taken in response to weather conditions taking into account the amount of energy already stored in the heater.

Set at 6 the heater takes a maximum charge and at 1 the heater takes a minimum charge at any room temperature. The casing of the heater, particularly in late evening, may feel cool, this is quite normal. The input control may require a few days experimentation before your comfort level is established.

Initially set the control to 3, the following evening if the room is too warm reduce to 2 or if it is too cool increase to 4. On subsequent evenings adjust by half divisions until your comfort level is achieved.

Having established the setting the input will automatically vary the amount of heat stored to compensate for weather conditions.

Output Controls

ROOM TEMPERATURE CONTROL

The room temperature control will allow the fan to run until the desired room temperature has been achieved. Once this has been reached the fan will automatically cycle ON and OFF to maintain this temperature. If the room feels too warm the room temperature control should be adjusted anticlockwise; conversely if the room feels too cool it should be adjusted clockwise.

BOOST OPTION

Boost selection is controlled by a two position illuminated rocker switch.

The boost option is only available when the fan is in operation.

When the Boost is switched ON, the direct acting

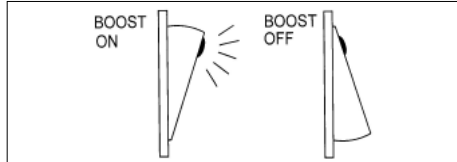

element will be automatically activated (in 2 stages) to supplement the heat output from a depleting core.

The switch will be illuminated whenever the fan is running, although safety devices within the heater will prevent the first stage of the direct acting element (half boost) being activated until the core is partially depleted.

When the core is almost fully depleted, the direct acting element will automatically switch to full power (full boost).

Dependent on the option the installer has chosen (see installation instructions point 4) the fan and boost will operate as follows:

Option 1 (two stage fan recommended for domestic installations)

- If boost option is not selected Normal Fan will operate.
- If boost option is selected, the fan will

automatically operate at Normal speed when half boost conditions apply.

- If boost option is selected, the fan will automatically operate at High speed when full boost conditions apply.

Option 2 (single stage fan - recommended for commercial installations)

- If boost option is not selected High fan will operate.
- If the boost option is selected, the fan will automatically operate at High speed when half boost conditions apply.
- If the boost option is selected, the fan will automatically operate at High speed when full boost conditions apply.

IMPORTANT

It is recommended that the boost function be switched OFF when the heater is not in use, especially overnight when the heater is charging.

During very warm weather, the fan alone may be used to circulate cool air.

CLEANING

To maintain the appearance of the heater, wipe occasionally with a dry cloth when the heater is cool. **Do not** use abrasive powders or furniture polish.

Discolouration of wall finishes can sometimes occur immediately above a storage heater due to the properties of some paints and decorating materials or the presence of environmental impurities in the air (such as soot or incense generated from the burning of candles, etc). A suitable shelf may be fitted to limit the extent of any wall discolouration.

AFTER SALES SERVICE

Your storage heater is guaranteed for two years from date of purchase. We undertake to exchange or repair within the period, any part found to be defective due to a manufacturing fault. This guarantee does not affect your statutory rights.

Should you require after sales service, please contact the supplier through whom you purchased the heater, or telephone Australia: 1300 556 816 New Zealand: 09 274 8265.

Please do not initially return a faulty appliance, or part of an appliance, to us as this may result in transit damage and/or a delay in providing service.

Let us know your difficulty quoting the model number and serial number (located along the wall bracket). We will then take the appropriate action.

RECYCLING



At the end of an electrical products useful life it should not be disposed of with household waste. Please recycle where facilities exist. Check with your Local Authority or retailer for recycling advice in your country.



This product complies with the European Safety Standards EN60335-2-30 and the European Standard Electromagnetic Compatibility (EMC) EN55014, EN60555-2 and EN60555-3. These cover the essential requirements of EEC Directives 2006/95/EC and 2004/108/EC

Australia:
Glen Dimplex Australia Pty Ltd
ABN 69 118 275 460
Unit 1, 21 Lionel Road
Mount Waverley VIC 3149

New Zealand:
Glen Dimplex Australiasia P/L
38 Harris Road
East Tamaki Auckland 2013

Tel: Australia: 1300 556 816
New Zealand: 09 274 8265

Web-site: Australia: www.dimplex.com.au or www.glendimplex.com.au
New Zealand: www.dimplex.co.nz or www.glendimplex.co.nz

10887 Issue 1

© GDC Group Ltd. All rights reserved. Material contained in this publication may not be reproduced in whole or in part, without prior permission in writing.
A division of the GDC Group Ltd, Millbrook House, Grange Drive, Hedge End, Southampton SO30 2DF



FXL_N

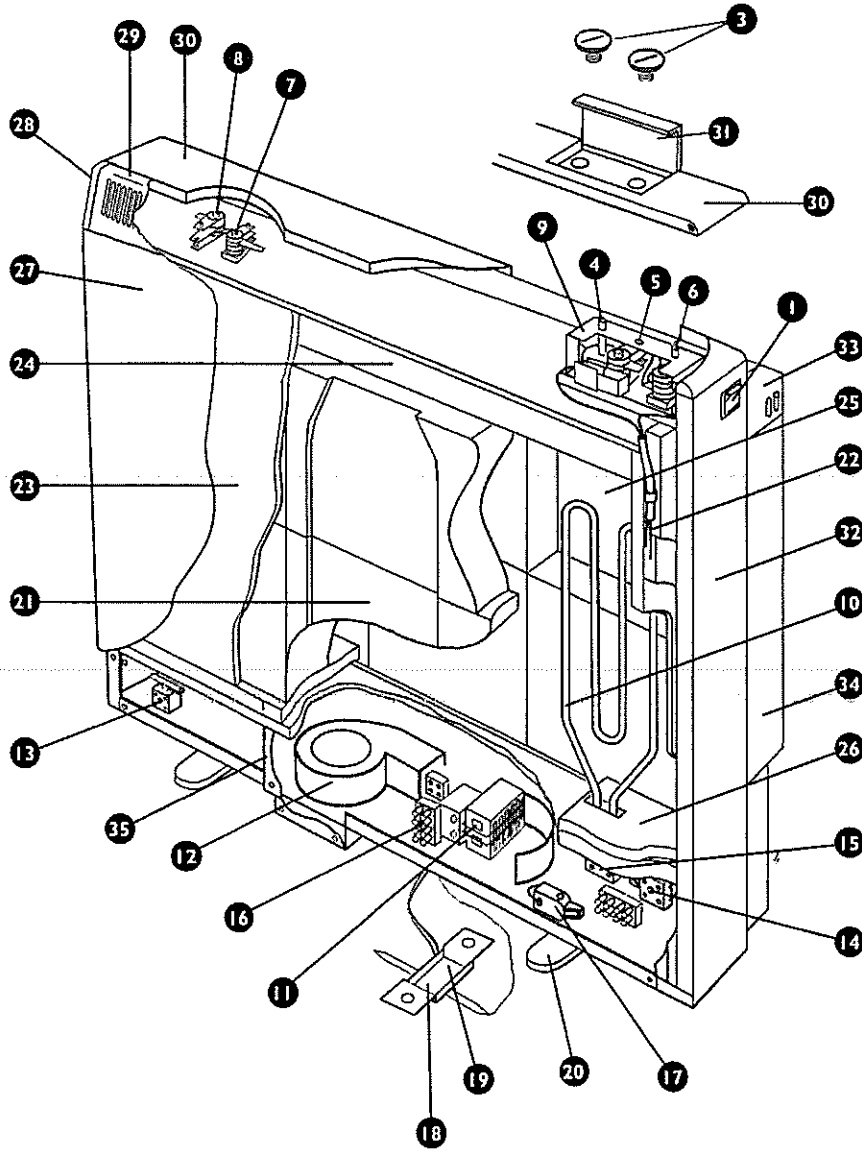

SPARES
LIST

Glen Dimplex Australasia FXL(i) SPARES LIST Series C

1	SWITCH - BOOST SWITCH ILLUMINATED	83083
3	CONTROL KNOB	83056
4	ROOM TEMPERATURE THERMOSTAT (SOPAC)	83338
5	LIMIT THERMOSTAT AND CUT OUT (TSB) FXL18i only	83342
	LIMIT THERMOSTAT AND CUT OUT (TSB) FXL24i only	83341
6	INPUT (TWIN SENSING) THERMOSTAT (INTER)	83101
7	STAT - BOOST THERMOSTAT 1 - 62°C ±3°C GREEN (TSB)	83206
8	STAT - BOOST THERMOSTAT 2 - 35°C ±3°C (TSB)	83207
9	CONTROL MOUNTING BRACKET	87022
10	ELEMENT 850W 240V	83136
11	BOOST ELEMENT 1500W ASSEMBLY	WMF-055S
12	FAN UNIT (REF AUO 73183)	91414
14	MAINS TERMINAL BLOCK	006062/0
15	ELEMENT TERMINAL BLOCK	80281
16	TERMINAL STRIP 10A (NYLON)	86858
17	MAINS CABLE CLAMP	80697S
18	PHIAL CLIP (TWIN SENSING)	80540
19	PHIAL CLIP (ROOM THERMOSTAT)	1/30212/0
20	FEET WILLOW WHITE (PAIR)	83096.7P
21	BRICK	83148D
22	WIRING LOOM FXL18i - WL128	10740
	WIRING LOOM FXL24i - WL127	10741
23	INNER FRONT C/W MICROPORE INSULATION FXL18i	83493S
	INNER FRONT C/W MICROPORE INSULATION FXL24i	83490S
24	INNER TOP INSULATION - MICROPORE FXL18i	83262
	INNER TOP INSULATION - MICROPORE FXL24i	83261
25	INNER BACK INSULATION - MICROPORE FXL18i	83265
	INNER BACK INSULATION - MICROPORE FXL24i	83264
26	INSULATION KIT FXL18i	83583
	INSULATION KIT FXL24i	83584
27	OUTER FRONT PANEL FXL18i WILLOW WHITE	83777.7
	OUTER FRONT PANEL FXL24i WILLOW WHITE	83789.7
28	GRILLE END CAP LH	83346
29	GRILLE FXL18i WILLOW WHITE	83776.7

Glen Dimplex Australasia FXL(i) SPARES LIST Series C

	GRILLE FXL24i WILLOW WHITE	83788.7
30	OUTER TOP & TOP BAFFLE ASSEMBLY FXL18i WILLOW WHITE	83021S.7
	OUTER TOP & TOP BAFFLE ASSEMBLY FXL24i WILLOW WHITE	83020S.7
31	CONTROL DOOR FXL(i) WILLOW WHITE	83085F
32	SIDE PANEL RH WILLOW WHITE	83501R.7
33	WALL FIXING BRACKET FXL18i BIRCH GREY	83026.8
	WALL FIXING BRACKET FXL24i BIRCH GREY	83025.8
34	REAR HEAT SHIELD FXL18i BIRCH GREY	83030.8
	REAR HEAT SHIELD FXL24i BIRCH GREY	83029.8
35	FAN MOTOR BOX COVER BLACK	83480.14
	EARTH SCREW ASSEMBLY	83855
	FAN SPEED RESISTOR	83872
	FIXING KIT	83976
	GRILLE END CAP RH	83345
	INNER GUARD LARGE	83782
	INNER GUARD SMALL	83783
	OMRON RELAY 10A G2R-1-T SPDT 240V~	83726
	RELAY SWITCH	83376
	SIDE PANEL LH WILLOW WHITE	83501L.7